



INTERNATIONAL UNION
OF RAILWAYS

DP-RAIL/DAC

Information for RFF IT Archi Fullteam

08 March 2022

14:00-15:30

Collaboration between the Rail Freight Forward (RFF) gamechangers is an opportunity to create synergies

DAC – Digital Automated Coupling

Goal:: to automatically couple and decouple the rolling stock in a freight train

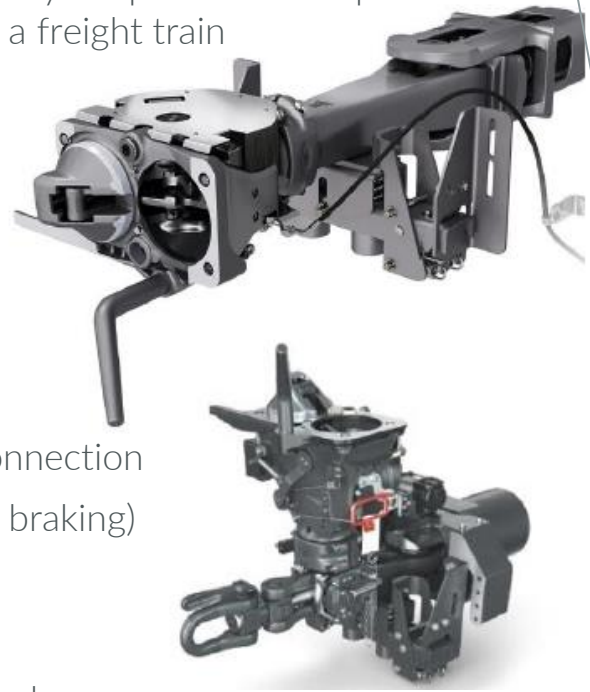

both physically
(the mechanical connection and the air line for braking)

as well as digitally
(electrical power and data connection).



DP-RAIL (Digital Platforms for Rail)

Goal:: to provide a “one-stop-shop” for operational data for a seamless data journey across Europe

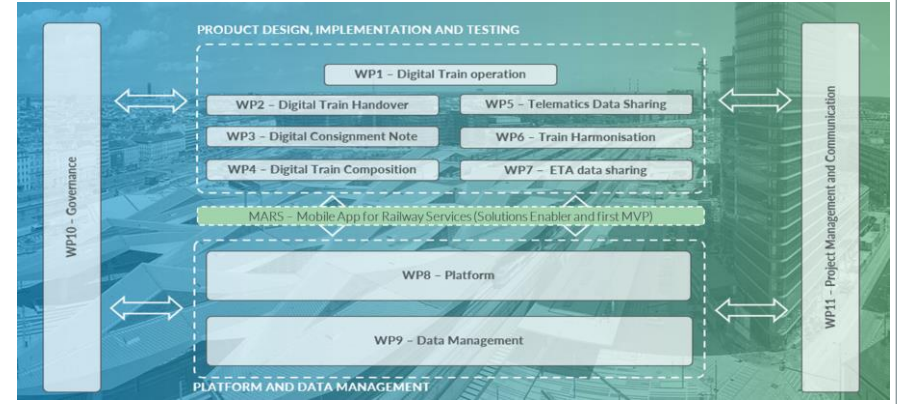

Opportunity for DP and DAC initiatives for close collaboration as DP-Rail ...

- Bundles the IT expertise of the rail freight sector
- May benefit in terms of practical use cases (e.g. digital train composition)

We held a first DAC/DP-RAIL workshop to address IT requirements for the DAC migration scenario

- EDDP WP3 Migration to work out the following aspects in Q1/2022
 - IT requirements for DAC migration
 - Approximate time required to prepare IT systems
 - Order of magnitude of required IT investments
- Opportunity for DP and DAC initiatives for close collaboration as DP-Rail ...
 - Bundles the IT expertise of the rail freight sector
 - May benefit in terms of practical use cases
- Lean workshop based approach proposed

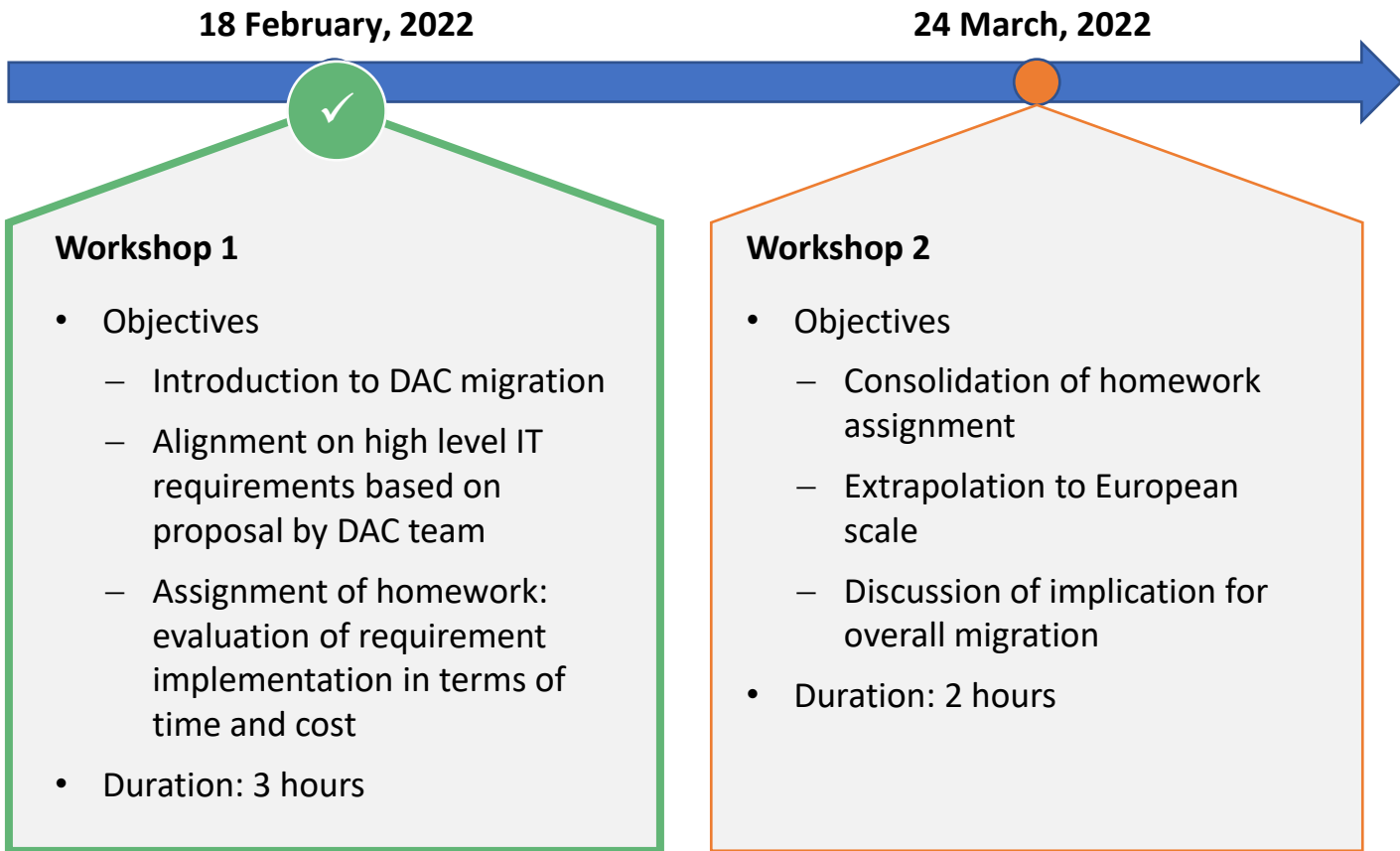

Participants were asked to guesstimate the required budget and time to realize the requirements

Required information on company level

- Overall IT budget need for all parties involved in DAC
- Overall realization timeline (assuming budget is available)

Scope

- Includes the realization of the above IT-requirements in the planning and operations IT of your own company
- Excludes potential further IT requirements for DAC migration planning/execution (e.g., simulations, capacity planning tools, etc.) and for the integration of the digital capacities of DAC

Aspired accuracy

- We aspire to develop the first guesstimate for IT costs of DAC migration on sector level – so far no information is available at all
- We will aggregate the feedback of the various stakeholders

Methodology

- You are free to choose a process to develop your guesstimate. Potentially, the following methodology could serve as guidance
 - Domain analysis for each IT requirements to identify IT applications impacted
 - Develop high level understanding of required changes
 - Estimate budget / time requirement based on analogy to previous projects
- Please provide estimates per requirement so that we can check completeness. We will not differentiate the resulting budget need on sector level by IT-requirement since we expect accuracy to be too low. Your estimates should focus on the cost of IT-development which we expect to be dominant

Going forward, we will continue to collaborate on an operative level and leverage know-how and resources

Workshop 3

Workshop 1

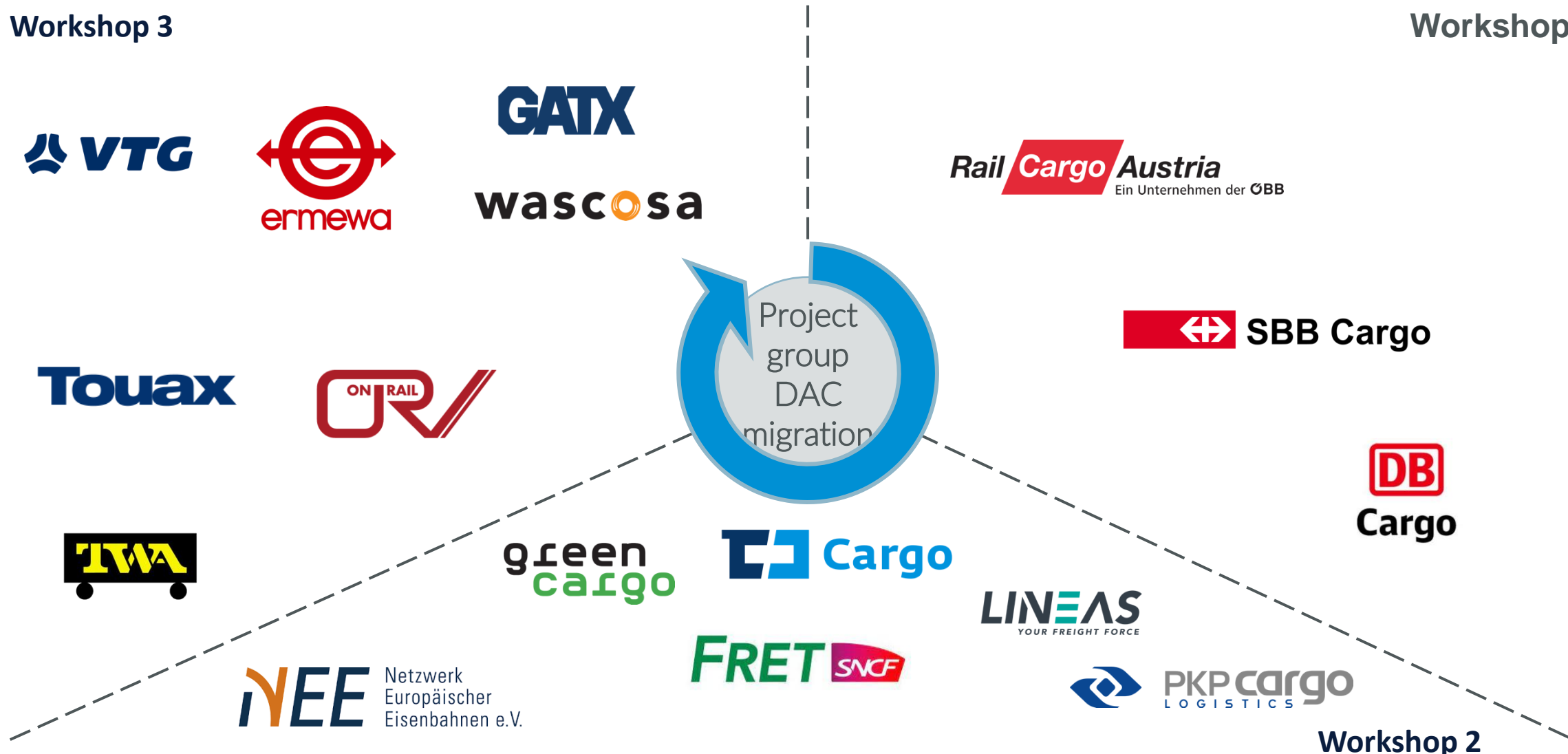

Project group
DAC
migration



Workshop 2



INTERNATIONAL UNION
OF RAILWAYS

DP-RAIL

Working Model

Information for RFF IT Archi Fullteam

08 March 2022

14:00-15:30

DP-RAIL Consortium

10 partners from 8 countries with networks covering Europe at large

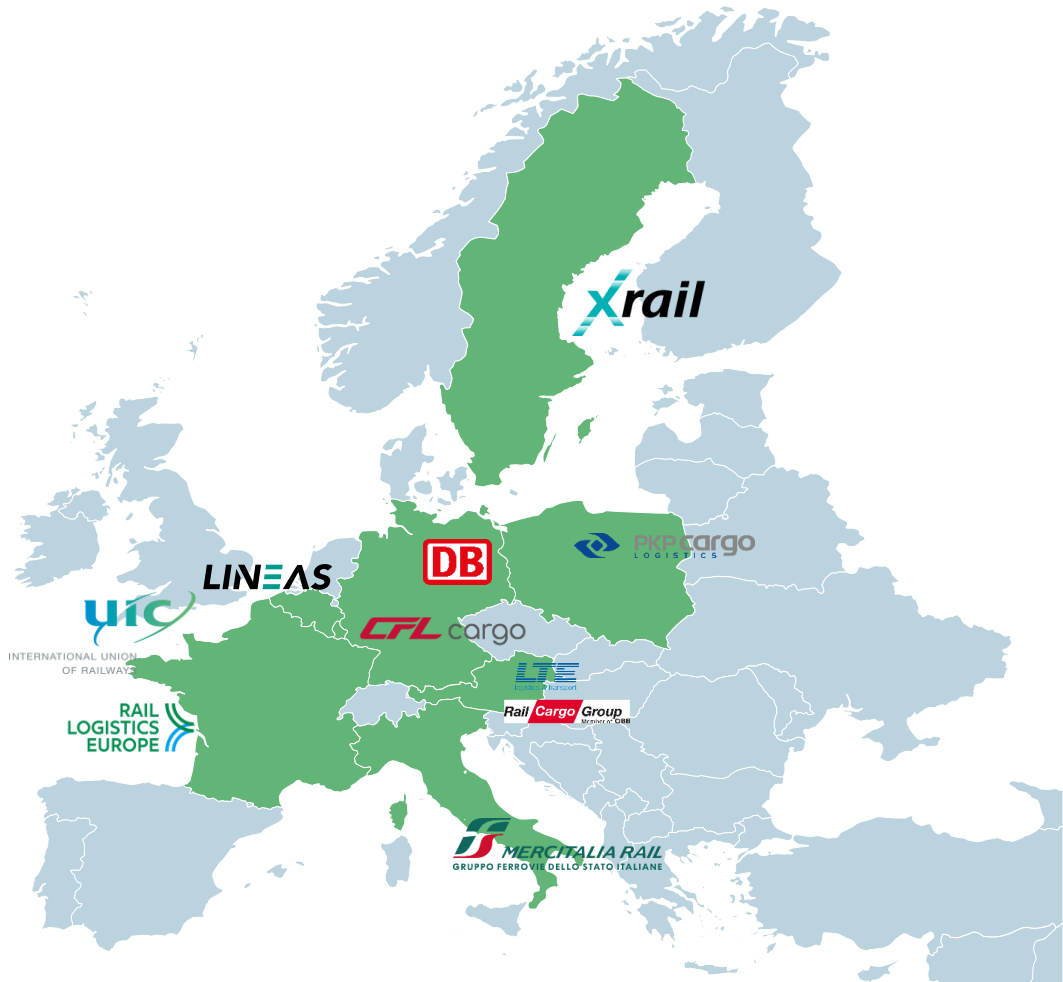

-  **CFL Cargo**, Luxemburg
-  **DB Cargo**, Germany
-  **Lineas**, Belgium
-  **LTE**, Austria
-  **Mercitalia Rail** and its affiliate **FS Technology**, Italy
-  **PKP Cargo**, Poland
-  **SNCF Fret** and its affiliate **RAIL4LOGISTICS**, France
-  **Rail Cargo Group**, Austria
-  **UIC** and its **Raildata** group of experts, France
-  **XRAIL**, Sweden

Recap: We strive to deliver 7 solutions for market uptake by 2025 by digitizing core rail operations

Recap of DP-RAIL

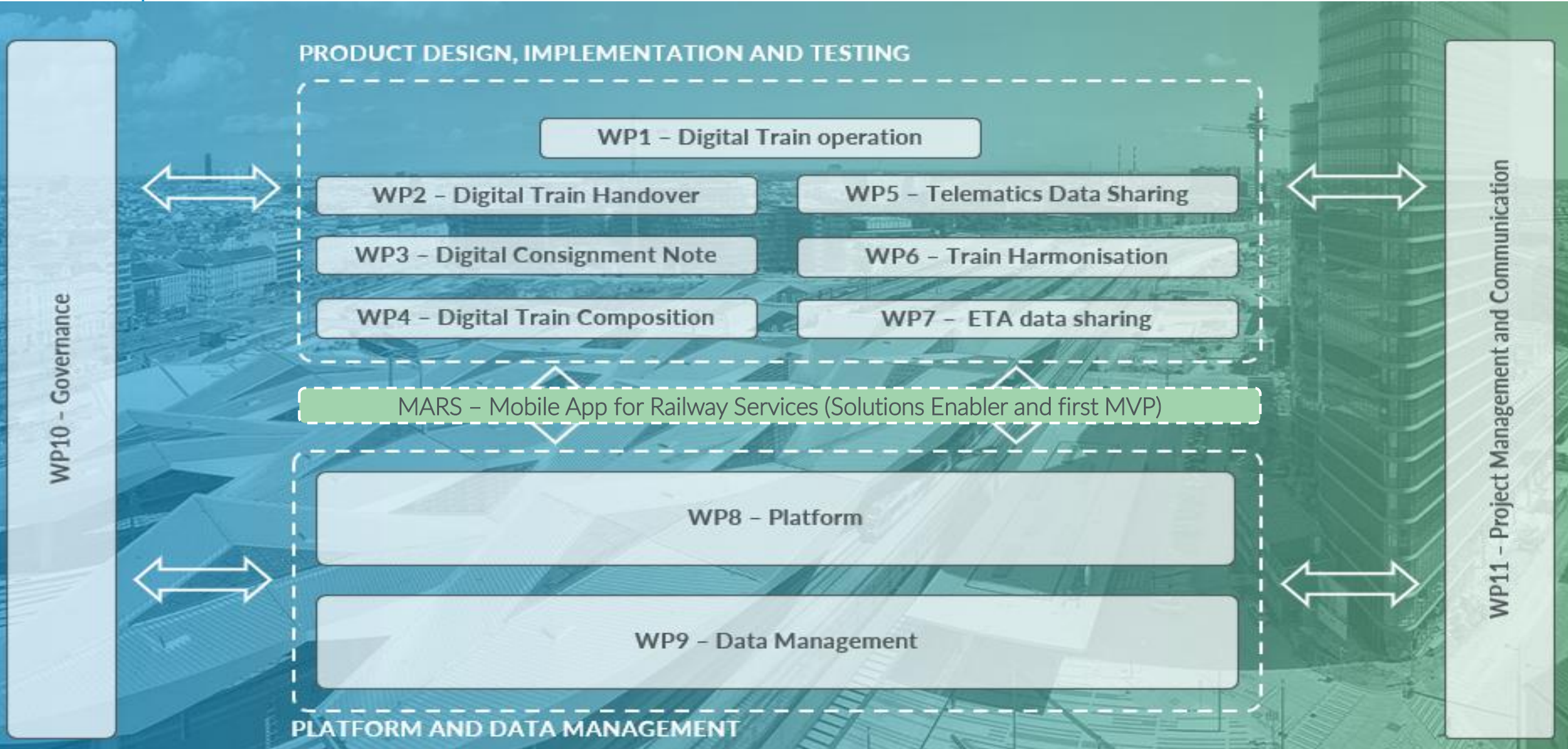

Agenda

Work organization until funding received

01

Targets until funding

02

Next Steps

03

Work organization paving the way for agile set up relying on DDT as main hands-on body

Proposed Work Organization - Overview

STEERING LEVEL

OPERATIVE LEVEL

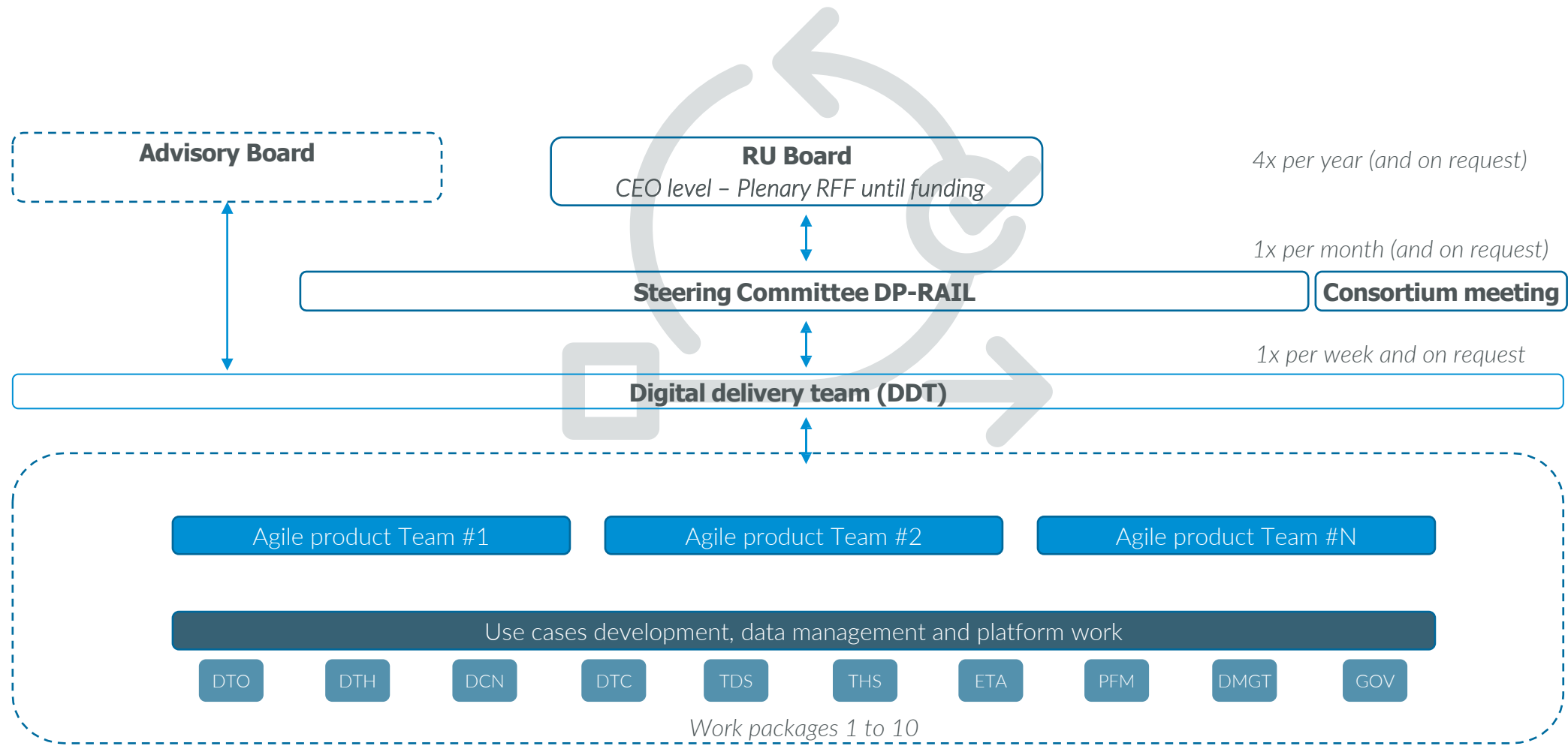

- Roles?
 - Product Owner(s) (1x pro Product Team) – Req. Eng.
 - Dev Lead(s) – Dev Team
 - User Community / Reps (Reflecting business value)
 - Architects
 - Transformation/Rollout Mgr.
 - Scrum Master
- Ceremonies and Process
 - Daily Standups
 - Sprint Review
 - Sprint Planning
 - Program Increment
 - Releases?
 - Big picture (how does it all fit together) SAFe Leitbild – DP Rail Variante
- Cross-Product Sync (Standards and Learnings)

The Digital Delivery Team (DDT) prioritizes work, tracks value creation and provides a unified view on project

Proposed Work Organization – Digital Delivery Team

STEERING LEVEL
OPERATIVE LEVEL

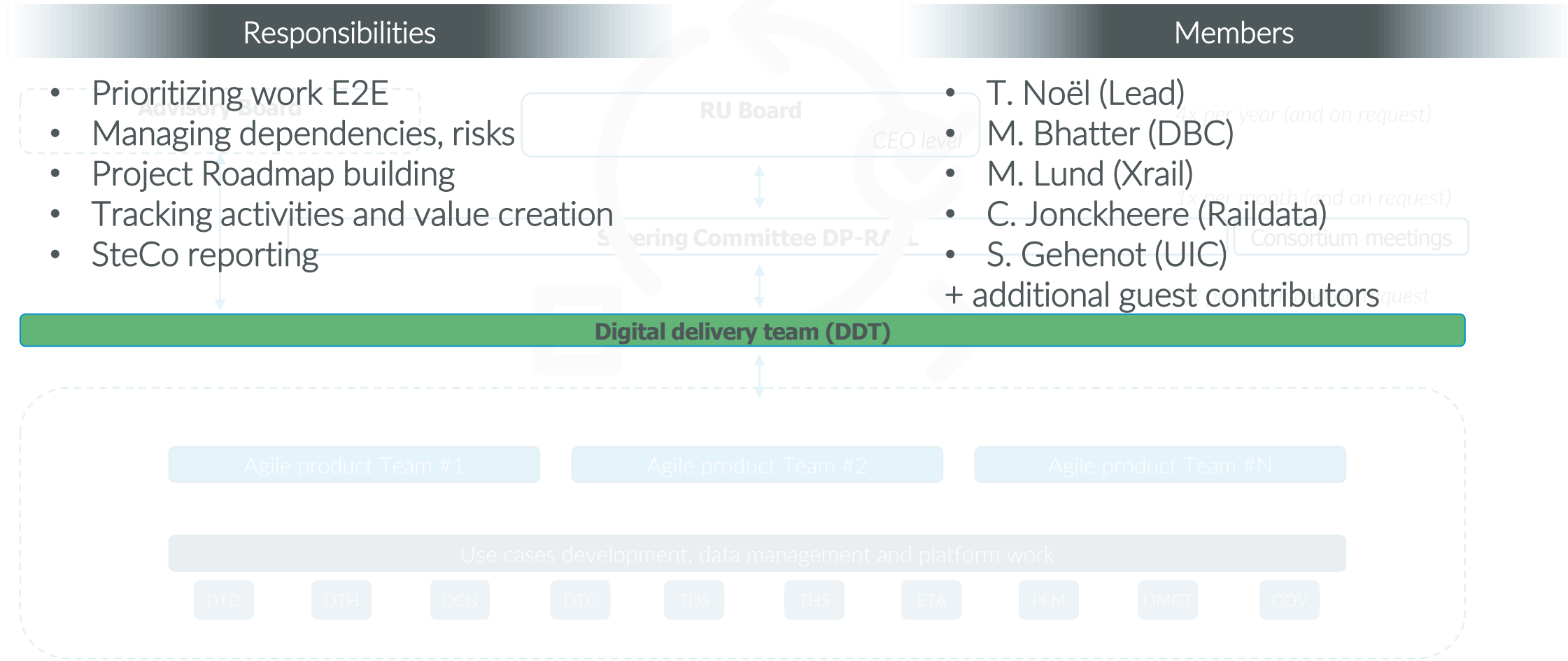

The DP-RAIL SteCo provides guidance and strategic direction and evaluates proposals made by the DDT

Proposed Work Organization – SteCo DP-RAIL

STEERING LEVEL

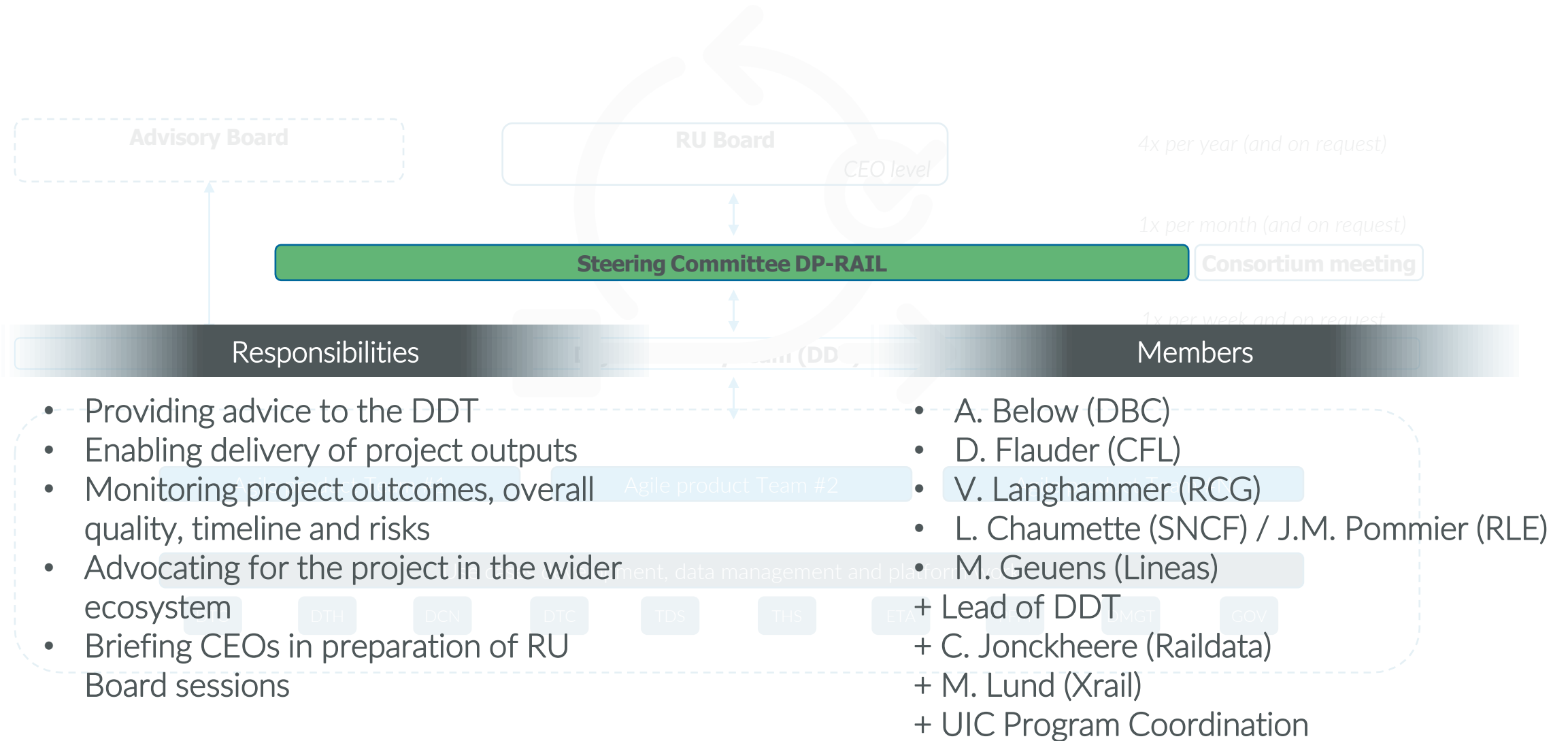

The DP-RAIL Consortium meetings is the primary sounding board for alignment on content and CEF admin

Proposed Work Organization – Consortium meeting

STEERING LEVEL

OPERATIVE LEVEL

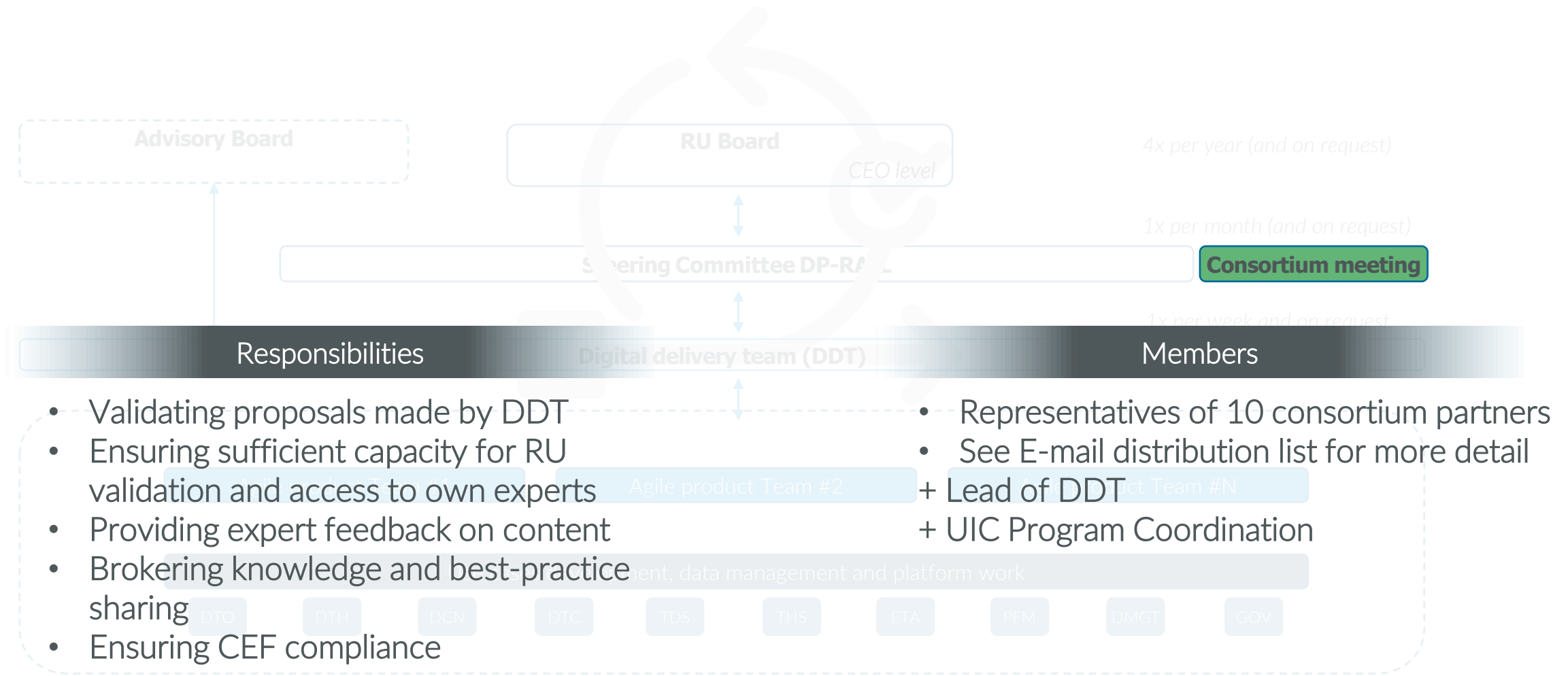

The RU Board is the CEO-level forum for long term strategic orientation and high-impact decision making

Proposed Work Organization – RU Board

STEERING LEVEL

OPERATIVE LEVEL

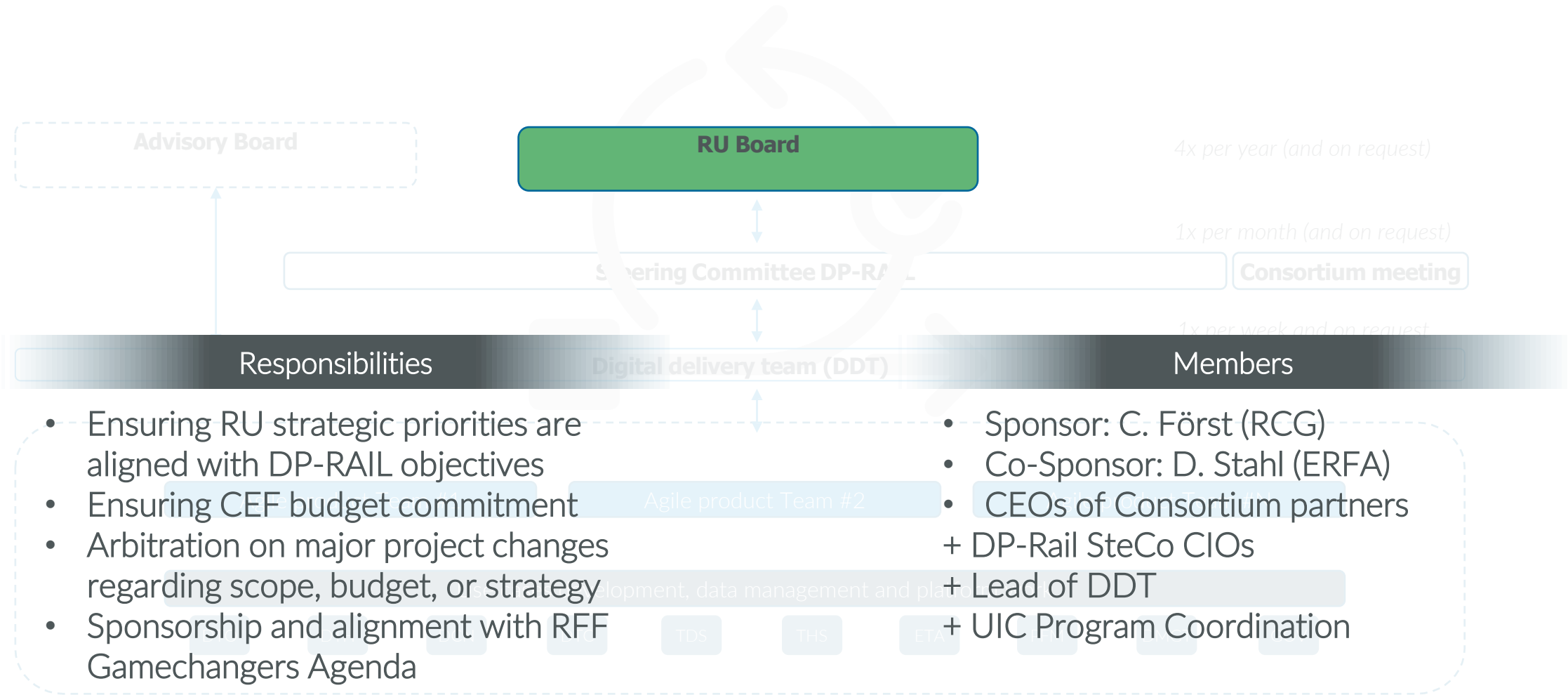

Agenda

Work organization until funding received

01

Targets until funding

02

Next Steps

03



“Beginning with the end in mind”; we believe a proper initiation phase for DP-RAIL is vital for success

Desired outcomes for PHASE II until Summer 2022

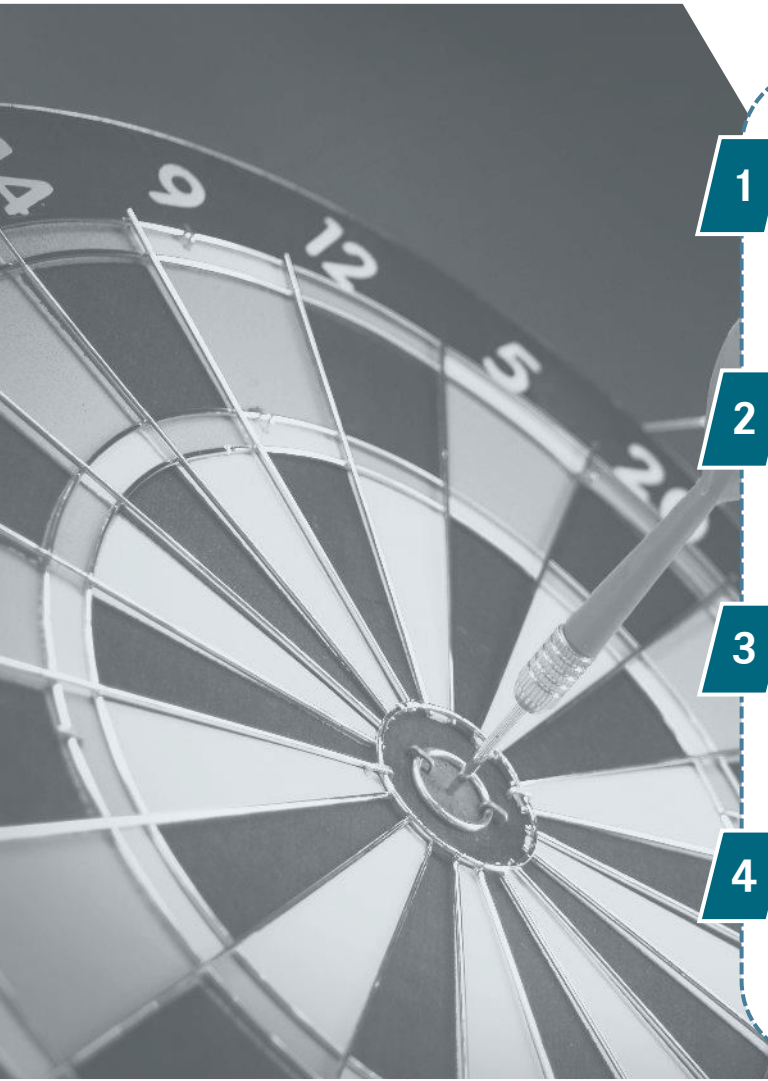

- 1** Achieve **shared understanding** within consortium of overall **DP-RAIL strategy**, agile **working mode** and **governance** (solutions, platform, data, consortium)
- 2** Have **foundations** for **product teams** in place: groomed **backlog** (at least epic level structures), solution purpose and “problem space” properly documented
- 3** Have an **architecture blueprint** for DP-RAIL documented including a description of core services, legacy integration and migration scenarios
- 4** **Manage existing meetings** such as RFF IT architecture full team and walk-in meetings to ensure we keep a **proper dialogue / communication** with experts and the wider community

Outcomes of Project Ramp-up Phase

We now fully shift our focus to preparing for project execution and scaling in 2022

Approach until Summer 2022

ACTIVITIES

MILESTONES

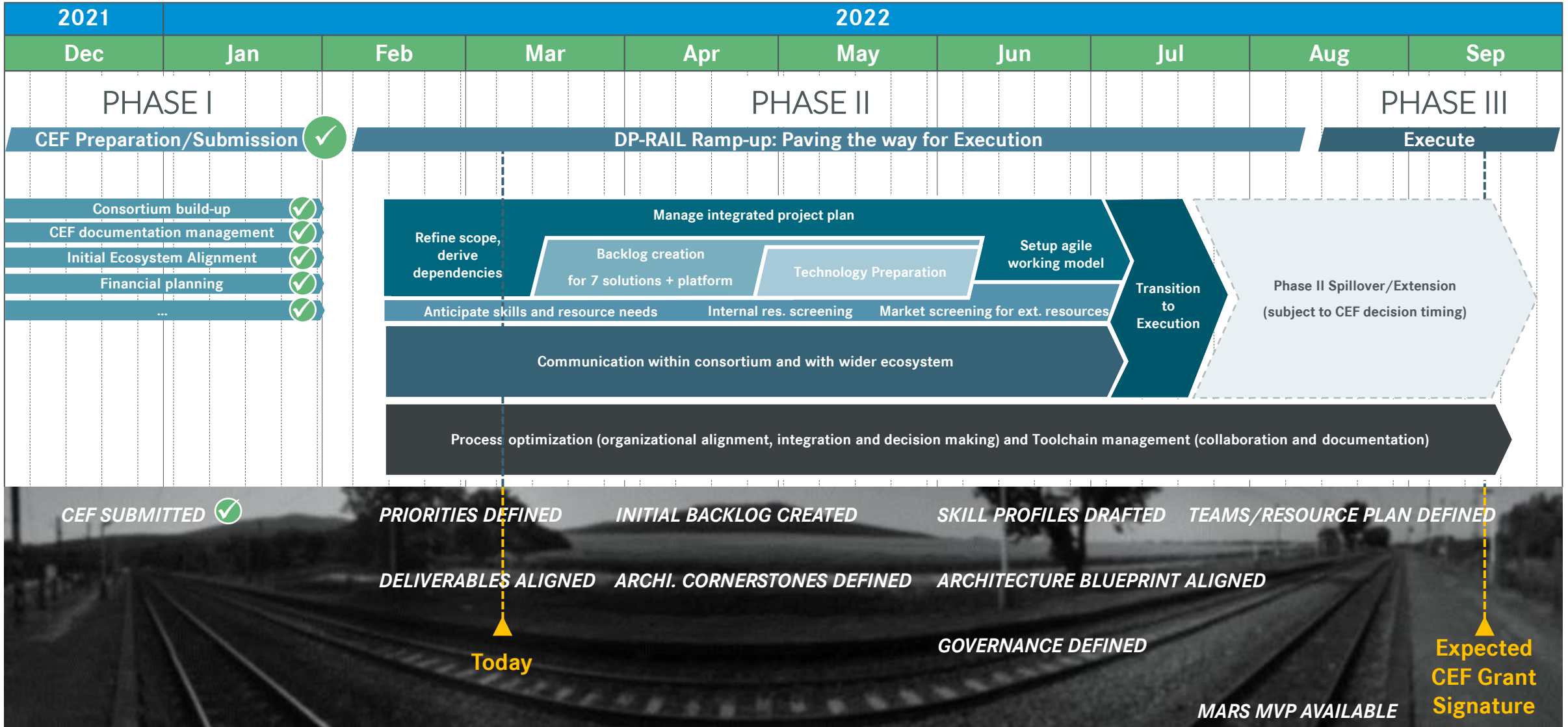

Agenda

Work organization until funding received

01

Targets until funding

02

Next Steps

03



Paving the way for DP-RAIL start, we will leverage existing resources for a lean setup until summer 2022

Xrail – Raildata – UIC joint priorities

3 Organizations. ONE ambition.



1
MARS MVP



...to enable digital communication between all transportation partners – incl. smaller RUs operating first / last mile & transit

2
PLATFORM



...to clarify our platform strategy and technology, along with core capabilities needed to support our 2025 vision

3
PROJECT RAMP-UP / GOVERNANCE

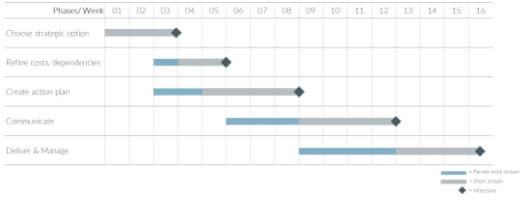

...to identify missing skills and resources, establish our agile working model, and prepare and align decision points